

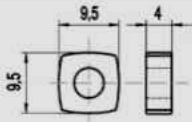









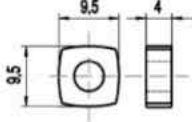

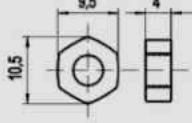

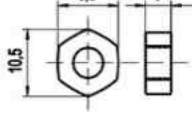

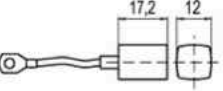

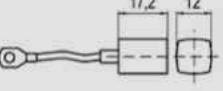

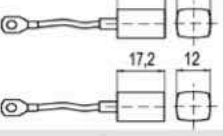

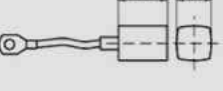

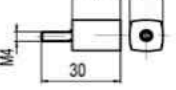



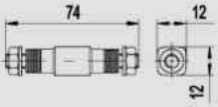

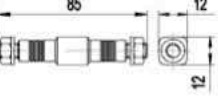
Welo Verschleissteile passend zu Agie - Maschinen

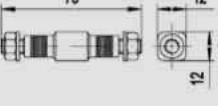
Stromzuführungen

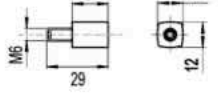
	Art. Nr.	Bezeichnung	
	1004	Stromzuführung Vierseiter beschichtet Verpackungseinheit 10 Stück Entspricht OEM-Nr. 199.484	
	1148	Stromzuführung Vierseiter Verpackungseinheit 10 Stück Entspricht OEM-Nr. 199.484	
	1006	Stromzuführung Sechsseiter beschichtet Verpackungseinheit 10 Stück	
	1149	Stromzuführung Sechsseiter Verpackungseinheit 10 Stück	
<p>Vier- und Sechsseiter passend für DEM 15 / DEM 25 / DEM 315 / DEM 315F / DEM 425 / DEM 740 / AC 50 / DEM 250 / DEM 250U / DEM 400 / DEM 700</p>			
	1005	Stromzuführung Vierseiter beschichtet Entspricht OEM-Nr. 326.824 passend für AC 100 / AC 200 / AC 300 / AC 100D / AC 200D / AC 300D	
	1138	Stromzuführung Vierseiter unbeschichtet Entspricht OEM-Nr. 358.684 passend für AC 100 / AC 200 / AC 300 / AC 100D / AC 200D / AC 300D	
	1290	Satz Stromzuführung Vierseiter passend für AC - Reihe oben beschichtet und unten unbeschichtet Entspricht OEM-Nr. 361.224	
	1320	Stromzuführung Vierseiter aus verkupfertem Wolfram passend für AC - Reihe Entspricht OEM-Nr. 400.474	
	1352	Stromzuführung Vierseiter mit Gewindeanschluß M4 Entspricht OEM-Nr. 424.934	

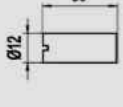
Welo Verschleissteile passend zu Agie - Maschinen

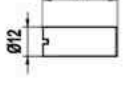

Stromzuführungen



Abmessungen	Art. Nr.	Bezeichnung	
	1212	Stromzuführung unten komplett Entspricht OEM-Nr. 385.804	
	1213	Stromzuführung oben komplett Entspricht OEM-Nr. 385.794	
	1217	Stromzuführung oben komplett Entspricht OEM-Nr. 408.154	
	1321	Obere Stromzuführung Vierseiter aus verkupfertem Wolfram mit Gewindeanschluß M6 Entspricht OEM-Nr. 424.914	
	1401	Obere Stromzuführung aus Wolfram - Kupfer Entspricht OEM-Nr. 443.474	
	1402	Untere Stromzuführung aus Hartmetall Entspricht OEM-Nr. 443.464	



Welo Verschleissteile passend zu Agie - Maschinen

Hochleistungs - Flachriemen

	Art. Nr.	Bezeichnung		
		Flachriemen passend für AC 100 / AC 100D		
	1092	Größe: 20 x 5700 mm Entspricht OEM-Nr. 331.404		
	1093	Größe: 20 x 5850 mm Entspricht OEM-Nr. 331.394		

	Art. Nr.	Bezeichnung	
		Flachriemen passend für AC 200 / AC 200D	
	1094	Größe: 20 x 5300 mm Entspricht OEM-Nr. 318.264	

	Art. Nr.	Bezeichnung	
		Flachriemen passend für AC 200D + H	
	1137	Größe: 20 x 5500 mm Entspricht OEM-Nr. 341.394	

	Art. Nr.	Bezeichnung	
		Flachriemen passend für AC 300 / AC 300D	
	1090	Größe: 20 x 7550 mm Entspricht OEM-Nr. 337.644	

Welo Verschleissteile passend zu Agie - Maschinen

Hochleistungs - Flachriemen



Art. Nr. Bezeichnung

- | | |
|-------------|---|
| | Flachriemen
passend für AC 300 + H |
| 1123 | Größe: 20 x 7800 mm
Entspricht OEM-Nr. 373.364 / 341.364 |
| 1133 | Größe: 20 x 7920 mm
Entspricht OEM-Nr. 373.354 |



Art. Nr. Bezeichnung

- | | |
|-------------|---|
| | Flachriemen
passend für AC 120 / AC150 / AC170 / HSS - Serie |
| 1201 | Größe: 20 x 6200 mm
Entspricht OEM-Nr. 407.734 |
| 1202 | Größe: 20 x 6600 mm
Entspricht OEM-Nr. 407.744 |



Art. Nr. Bezeichnung

- | | |
|---------------|---|
| | Flachriemen
passend für AC 220 / AC250 / AC270 |
| 1203 | Größe: 20 x 6140 mm
Entspricht OEM-Nr. 400.884 |
| 1203-1 | Größe: 20 x 6000 mm
Entspricht OEM-Nr. 447.294 |
| 1204 | Größe: 20 x 5930 mm
Entspricht OEM-Nr. 396.554 |



Art. Nr. Bezeichnung

- | | |
|-------------|---|
| | Flachriemen
passend für AC 300 / AC320 / AC350 / AC370 |
| 1210 | Größe: 20 x 8500 mm
Entspricht OEM-Nr. 407.844 |
| 1211 | Größe: 20 x 8300 mm
Entspricht OEM-Nr. 400.914 |



Welo Verschleissteile passend zu Agie - Maschinen

Hochleistungs - Flachriemen



Art. Nr.	Bezeichnung
----------	-------------

	Flachriemen passend für AC 320 / AC 350 / AC 370
--	---

1260	Größe: 20 x 6090 mm Entspricht OEM-Nr. 421.084
-------------	---

1261	Größe: 20 x 6380 mm Entspricht OEM-Nr. 421.094
-------------	---



Welo Verschleissteile passend zu Agie - Maschinen

Hochleistungs - Zahnriemen

Wagenmodell	Art. Nr.	Bezeichnung	
	1319	Zahnriemen Entspricht OEM-Nr. 689.587 / 590689587	
	1254	Zahnriemen Entspricht OEM-Nr. 665.087	
	1394	Zahnriemen passend für AC - Sprint und HSS - Serie Entspricht OEM-Nr. 685.097	

Welo Verschleissteile passend zu Agie - Maschinen

Hochleistungs - Filtermatten











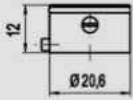

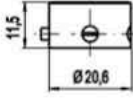

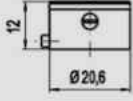

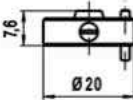

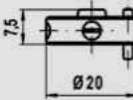

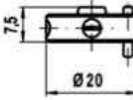

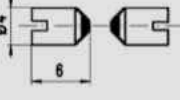
Art. Nr.	Bezeichnung
	Filtermatten
1027	Größe: 565 x 585 mm
1058	Größe: 560 x 380 mm Entspricht OEM-Nr. 202.377
1059	Größe: 480 x 300 mm Entspricht OEM-Nr. 201.557
1060	Größe: 450 x 380 mm Entspricht OEM-Nr. 202.007
1061	Größe: 430 x 370 mm Entspricht OEM-Nr. 202.457
1062	Größe: 480 x 200 mm Entspricht OEM-Nr. 201.577
1063	Größe: 570 x 300 mm Entspricht OEM-Nr. 202.367
1064	Größe: 380 x 380 mm Entspricht OEM-Nr. 202.397
1065	Größe: 370 x 290 mm Entspricht OEM-Nr. 202.607
1115	Rollenware ca. 13 mm dick Zuschnitt nach Ihren Wünschen Berechnung pro m ²
1115-1	Rollenware ca. 20 mm dick Zuschnitt nach Ihren Wünschen Berechnung pro m ²

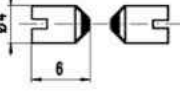

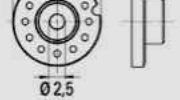







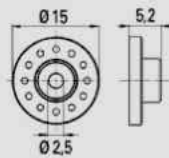

Welo Verschleissteile passend zu Agie - Maschinen

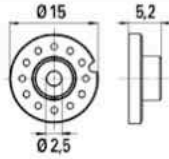
Drahtführungen

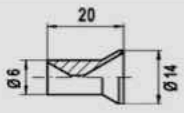
	Art. Nr.	Bezeichnung	
	1136	Drahtführungssatz oben komplett Entspricht OEM-Nr. 323.314 oder 417.974	
	1369	Drahtführungssatz oben komplett Entspricht OEM-Nr. 417.984	
	1370	Drahtführungssatz oben komplett Entspricht OEM-Nr. 362.064	
	1135	Drahtführungssatz unten komplett Entspricht OEM-Nr. 323.304	
	1371	Drahtführungssatz unten komplett Entspricht OEM-Nr. 418.004	
	1372	Drahtführungssatz unten komplett Entspricht OEM-Nr. 362.054	
	1070	Diamant - Drahtführung (1 Satz = 2 Stück) bitte bei Bestellungen 2 Stück bestellen Entspricht OEM-Nr. 326.834	
	1199	Nachschleifen von PKD - Drahtführung Art.-Nr. 1070 (1 Satz = 2 Stück) bitte bei Bestellungen 2 Stück bestellen	
	1710	Drahtführung d= 2,5 R. 0,5 mm passend für AC Classic / Evolution Entspricht OEM Nr. 239.183	
	1711	Drahtführung d= 2,5 R. 0,5 mm inox passend für AC Challenge / Classic / Evolution / und Excellence Entspricht OEM Nr. 262.163 / 590262163	

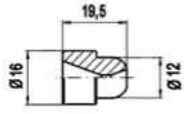
Welo Verschleissteile passend zu Agie - Maschinen

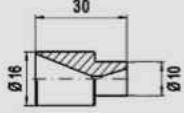
Drahtführungen

	Art. Nr.	Bezeichnung	
	1763	Dummy Drahtführung d= 2,5 mm Inox passend für AC Challenge / Classic / Progress und Vertex 2 / 3 Entspricht OEM Nr. 262.213	
	1764	Dummy Drahtführung d= 2,5 mm Inox passend für AC Evolution und Excellence Entspricht OEM Nr. 261.733	
	1071	Saphir untere Führung Entspricht OEM-Nr. 326.844	
	1072	Keramik - Drahtfang unten Entspricht OEM-Nr. 326.294	
	1073	Keramik - Einlauf Entspricht OEM-Nr. 326.864	

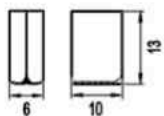









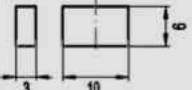

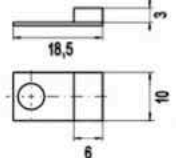
Art. Nr. Bezeichnung

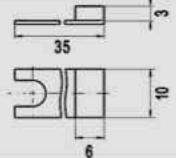
	Saphir Drahtführung	
1010	für Drahtdurchmesser = 0,05 mm Entspricht OEM-Nr.167.733	
1012	für Drahtdurchmesser = 0,10 mm Entspricht OEM-Nr.158.283	
1014	für Drahtdurchmesser = 0,15 mm Entspricht OEM-Nr.158.293	
1016	für Drahtdurchmesser = 0,20 mm Entspricht OEM-Nr.158.303	
1020	für Drahtdurchmesser = 0,25 mm Entspricht OEM-Nr 170.973	
1022	für Drahtdurchmesser = 0,30 / 0,35 mm Entspricht OEM-Nr.158.313 / 295.144	

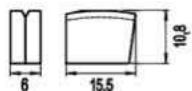





Welo Verschleissteile passend zu Agie - Maschinen

Drahtführungen

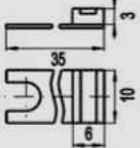
	Art. Nr.	Bezeichnung	
	1021	Saphir - Anpress - Stück zum Einkleben	
	1038	Saphir - Anpress - Stück komplett mit Halter kurze Ausführung Entspricht OEM-Nr. 291.264 / 249.854 Alle Drahtführungen passend für DEM 315 / DEM 315F / DEM 425 / DEM 740 / AC 50 / DEM 250 / DEM 250U / DEM 400 / DEM 700	
	1081	Saphir - Anpress - Stück komplett mit Halter lange Ausführung Entspricht OEM-Nr. 291.264	
	1025	Drahtführung passend für ältere Maschinentypen z.B. DEM 15 Entspricht OEM-Nr. 217.974	
	1026	Drahtführung passend für ältere Maschinentypen z.B. DEM 15 / DEM 25 / DEM 30 Entspricht OEM-Nr. 236.264	

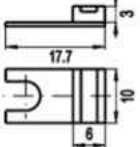
Welo Verschleissteile passend zu Agie - Maschinen

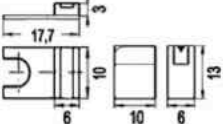
Drahtführungen

	Art. Nr.	Bezeichnung	
	1084	PKD - Anpress - Stück lang komplett mit Halter Bitte separat angeben	
	1089	PKD - Anpress - Stück kurz für Diamantführung	
	Art. Nr.	Bezeichnung PKD - Drahtführung bestehend aus: 1 Stück Führung und 1 Stück Anpress Stück Ein kompletter Satz PKD - Führungen für eine Maschine besteht aus 2 Führungen und 2 Anpress - Stücken Der angegebene Preis bezieht sich auf 1 Stück Führung und 1 Stück Anpress - Stück Bitte beachten Sie dies bei Ihrer Bestellung	
	1088	für Drahtdurchmesser 0,05 mm	
	1087	für Drahtdurchmesser 0,10 mm	
	1086	für Drahtdurchmesser 0,15 mm	
	1080	für Drahtdurchmesser 0,20 mm	
	1085	für Drahtdurchmesser 0,25 mm	
	1096	für Drahtdurchmesser 0,30 mm	











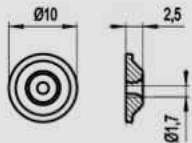

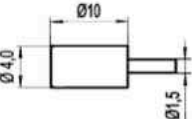

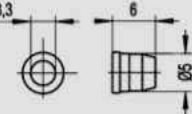

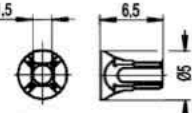

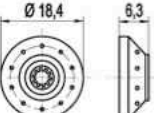

Welo Verschleissteile passend zu Agie - Maschinen

Düsen

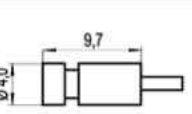
	Art. Nr.	Bezeichnung	
	1067	Innendüse komplett zur Führungseinheit Entspricht OEM-Nr. 326.264	
	1068	Standarddüse zur Führungseinheit Ausführung: Kunststoff Entspricht OEM-Nr. 185.303	
	1324	Spezial Düse mit O - Ring Ausführung: Kunststoff Entspricht OEM-Nr. 419.514	
	1170	Standarddüse zur Führungseinheit mit austauschbarem Keramikteil Ausführung: VA / Keramik Entspricht OEM-Nr. 323.254	
	1175	Reparatur Standarddüse Art. Nr. 1170 Neues Keramikteil	
	1331	Spezial Düse Innendurchmesser 0,7 mm mit O - Ring Ausführung: VA / Keramik Entspricht OEM-Nr. 419.524	
	1066	Speed - Set Düse Entspricht OEM-Nr. 337.944	
	1374	Innendüse Spezial Entspricht OEM-Nr. 362.534	
	1373	Innendüse mit O - Ring Entspricht OEM-Nr. 419.484	
	1250	Innendüse komplett Entspricht OEM-Nr. 419.054	

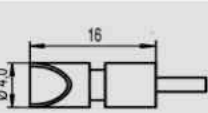

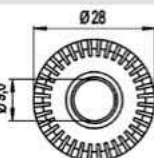



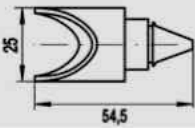

Welo Verschleissteile passend zu Agie - Maschinen

Düsen

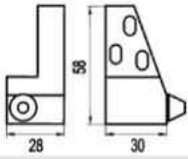
	Art. Nr.	Bezeichnung	
	1322	Keramik Aussendüse Entspricht OEM-Nr. 419.064	
	1267	Blasdüse zur Bremse passend für HSS Serie Entspricht OEM-Nr. 351.764	
	1259	Hülse für Gehäuse Entspricht OEM-Nr. 353.124	
	1268	Schikane zur Feinstrahldüse Entspricht OEM-Nr. 352.924	
	1745	Düse passend für AC Classic und Evolution Entspricht OEM Nr. 250.613	
	1756	Düse passend für AC Evolution / Excellence und Vertex Entspricht OEM Nr. 250.433	
	1757	Düse passend für AC Challenge / Classic / Evolution / Excellence / Progress und Vertex Entspricht OEM Nr. 250.943	
	1719	Düse passend für AC Classic / Evolution Entspricht OEM Nr. 443.334	
	1720	Düse + F passend für AC Challenge / Classic / Evolution / Excellence / Progress und Vertex Entspricht OEM Nr. 459.524	
	1722	Düse Inox d= 9,0 D= 28 mm passend für AC Classic / Evolution Entspricht OEM Nr. 199.272	

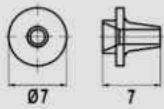

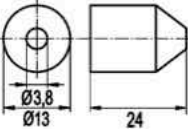







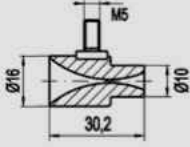

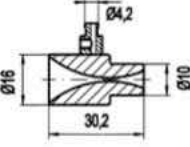

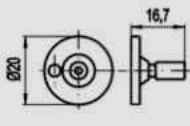

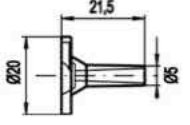

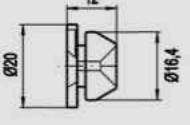

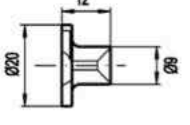
Welo Verschleissteile passend zu Agie - Maschinen

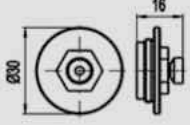
Düsen

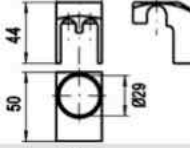
Welo Artikel	Art. Nr.	Bezeichnung	
	1724	Düse Inox passend für AC Classic / Evolution Entspricht OEM Nr. 250.623	
	1488	Düse zum Drahtabzug passend für AC Challenge / Classic Evolution / Excellence und Progress Entspricht OEM-Nr. 834.244	
	1491	Innendüse passend für AC Challenge / Classic / Evolution / Excellence / Progress und Vertex Entspricht OEM-Nr. 426.494	
	1494	Keramikdüse passend für Drahtabzug Welo Art.Nr. 1488	

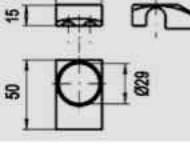
Welo Verschleisssteile passend zu Agie - Maschinen

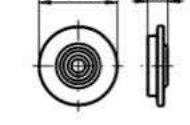
Allgemeine Verschleiss- und Ersatzteile

	Art. Nr.	Bezeichnung	
	1223	HM - Einlauf mit Schraube Entspricht OEM-Nr. 343.074	
	1224	HM - Einlauf komplett Entspricht OEM-Nr. 361.994	
	1069	Saugrohr unten Verpackungseinheit 5 Stück Entspricht OEM-Nr. 338.184	
	1219	Saugrohr passend für Sprint - Serie Entspricht OEM-Nr. 396.414	
	1225	Saugrohr passend für AC - Reihe Entspricht OEM-Nr. 419.374	
	1297	Saugtrichter passend für HSS - Serie Verpackungseinheit 5 Stück Entspricht OEM-Nr. 419.594	
	1406	Saugrohr passend für HSS - Serie Entspricht OEM-Nr. 251.563.3	
	1256	Abdeckung aus Kunststoff schwarz Entspricht OEM-Nr. 164.732	
	1269	Abdeckung aus Kunststoff schwarz Entspricht OEM-Nr. 155.502	
	1366	Wippe Entspricht OEM-Nr. 419.314	





Welo Verschleisssteile passend zu Agie - Maschinen

Allgemeine Verschleiss- und Ersatzteile

	Art. Nr.	Bezeichnung	
	1376	Wasserfiltereinsatz Entspricht OEM-Nr. 646.847	
	1355	Gehäuse Entspricht OEM-Nr. 352.904	
	1296	Lagerdeckel passend für HSS - Serie Entspricht OEM-Nr. 326.754	
	1221	Balg passend für Sprint - Maschinen Entspricht OEM-Nr. 178.222 / 173.952	
	1122	Balg passend für Speed - Set Entspricht OEM-Nr. 180.683	
	1312	Balg Entspricht OEM-Nr. 155.562	
	1311	Balg Entspricht OEM-Nr. 155.592	
	1295	Balghalter passend für HSS - Maschinen Entspricht OEM-Nr. 155.622	
	1294	Gewinding komplett Entspricht OEM-Nr. 426.364	
	1134	Gewinding passend für Speed - Set Entspricht OEM-Nr. 338.864	

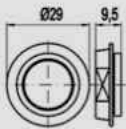
Welo Verschleisssteile passend zu Agie - Maschinen

Allgemeine Verschleiss- und Ersatzteile

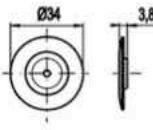
	Art. Nr.	Bezeichnung	
	1255	Gewinding passend für HSS - Maschinen Entspricht OEM-Nr. 400.754	
	1141	Zentrierung passend für AC - Maschinen Entspricht OEM-Nr. 185.343	
	1173	Spüldeckel zu Conofil passend für AC 100 / 300 Entspricht OEM-Nr. 326.764	
	1174	Drahtfang ausen Conofil passend für AC 100 / 300 Entspricht OEM-Nr. 326.334	
	1205	Drahtfang innen Conofil passend für AC 100 / 300 Entspricht OEM-Nr. 326.644	
	1300	Büchse passend für HSS - Maschinen Entspricht OEM-Nr. 387.974	
	1293	Zwischenstück 0,05 mm Stärke Entspricht OEM-Nr. 441.574	
	1208	Spüldeckel für Speed - Set Düse passend zu Welo Nr. 1066 Entspricht OEM-Nr. 327.104	
	1075	Bremsring (1 Satz = 2 Stück) bitte bei Bestellungen 2 Stück bestellen Entspricht OEM-Nr. 326.604	
	1354	Bremsringeinheit komplett montiert Entspricht OEM-Nr. 199.683	









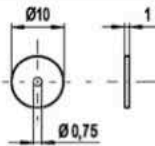

Welo Verschleisssteile passend zu Agie - Maschinen

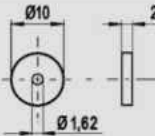
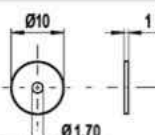
Allgemeine Verschleiss- und Ersatzteile

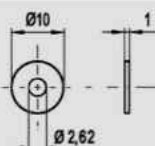
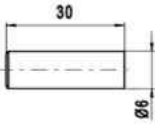
	Art. Nr.	Bezeichnung	
	1404	Bremsring in Keramikausführung für feine Drähte (1 Satz = 2 Stück) passend für Evolution bitte bei Bestellungen 2 Stück bestellen Entspricht OEM-Nr. 459.494	
	1360	Magnetbremsträger Entspricht OEM-Nr. 174.122	
	1140	Bürste zur Bremse Entspricht OEM-Nr. 323.474	
	1323	Bürste komplett Entspricht OEM-Nr. 304.194	
	1305	Bürstensatz Verpackungseinheit 8 Stück Entspricht OEM-Nr. 826.508	
	1214	Abdeckung passend für Sprint - Serie Entspricht OEM-Nr. 386.024	
	1215	Lagerschale Entspricht OEM-Nr. 326.444	
	1222	Spüldeckel passend für Sprint - Serie Entspricht OEM-Nr. 385.284 oder OEM-Nr. 408.014	
	1226	Fächer Entspricht OEM-Nr. 387.834	
	1368	Fächer Entspricht OEM-Nr. 419.234	

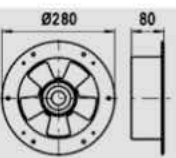
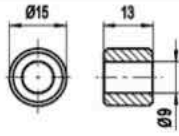

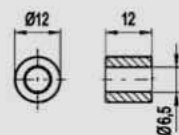
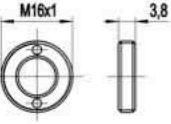







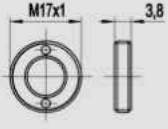

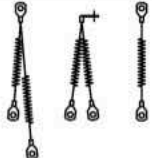

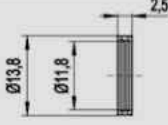

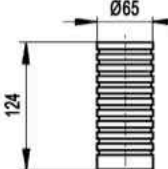

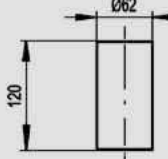
Welo Verschleisssteile passend zu Agie - Maschinen

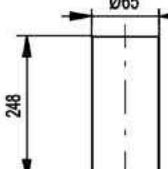
Allgemeine Verschleiss- und Ersatzteile

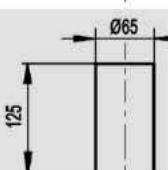
	Art. Nr.	Bezeichnung	
	1367	Fächer Entspricht OEM-Nr. 191.613	
	1292	Saphirring d= 0,75 mm Entspricht OEM-Nr. 395.444	
	1289	Saphirring d= 1,62 mm Entspricht OEM-Nr. 326.734	
	1227	Saphirring d= 1,70 mm Entspricht OEM-Nr. 387.824	
	1291	Saphirring d= 2,62 mm Entspricht OEM-Nr. 380.354	
	1241	Blasrohr für Bremse Entspricht OEM-Nr. 351.774	
	1330	Ventilator 220V AE - 200 Entspricht OEM-Nr. 170.337	
	1308	Messing Distanzhülse Entspricht OEM-Nr. 326.704	
	1309	Distanzstück Entspricht OEM-Nr. 326.354	
	1307	Druckschraube Entspricht OEM-Nr. 418.294	

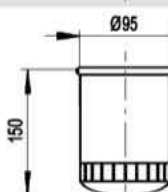
Welo Verschleisssteile passend zu Agie - Maschinen

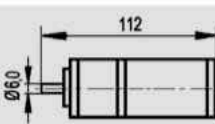
Allgemeine Verschleiss- und Ersatzteile

	Art. Nr.	Bezeichnung	
	1353	Druckschraube	
	1164	Satz Spiralschnüre passend für AC - Serie (1 Satz = 3 Stück) Entspricht OEM-Nr. 319.184	
	1377	Federring Entspricht OEM-Nr. 426.724	
	1114	Polzeifilter - Element passend für Agie Filterfeinheit 75 µm Entspricht OEM-Nr. 656.627	
	1114-2	Polzeifilter - Element passend für Agie Filterfeinheit 5 µm neue weiße Ausführung Entspricht OEM-Nr. 673.547	
	1114-4	Filterelement passend für Agie / Charmilles / Makino / Sodick / Agemaspark / Eurospark und Hurco Filterfeinheit 5 µm weiße Ausführung	
	1114-5	Polzeifilter - Element passend für Agie Filterfeinheit 75 µm frühere Ausführung Entspricht OEM-Nr. 673.547	
	1233	Filterpatrone W 940 Oelfilter Entspricht OEM-Nr. 643.107	
	1762	DC - Motor mit Getriebe 48 V / 15 W und Anschlusskabel Entspricht OEM-Nr. 171.227	

Welo Verschleisssteile passend zu Agie - Maschinen

Allgemeine Verschleiss- und Ersatzteile

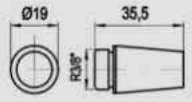
	Art. Nr.	Bezeichnung	
	1326	Kolben Entspricht OEM-Nr. 315.874	
	1358	Teleskop komplett Entspricht OEM-Nr. 323.404	
	1356	Achsbolzen Entspricht OEM-Nr. 323.164	
	1357	Achsbolzen Entspricht OEM-Nr. 323.174	
	1375	Achsbolzen Entspricht OEM-Nr. 326.484	
	1365	Scheibe Entspricht OEM-Nr. 418.594	
	1329	Schalldämpfer R= 3/8" Entspricht OEM-Nr. 666.697	
	1257	Magnetventil G= 3/4" 220V 50 / 60Hz Entspricht OEM-Nr. 345.024 oder OEM-Nr. 691.607	
	1389	Spüldeckel Entspricht OEM-Nr. 184.363	
	1451	Gabel unten Entspricht OEM-Nr. 414.604 oder 351.644 (alt)	











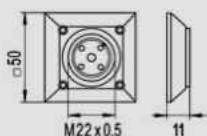

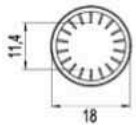

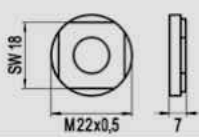

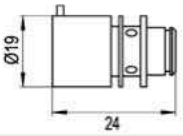

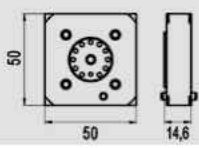
Welo Verschleisssteile passend zu Agie - Maschinen

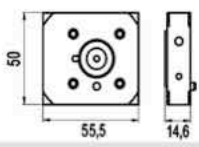
Allgemeine Verschleiss- und Ersatzteile

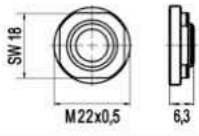
	Art. Nr.	Bezeichnung	
	1452	Gabel oben rechts Entspricht OEM-Nr. 235.853.9 oder 377.704 (alt)	
	1735	Kohlebürste 4 x 4 x 15 mm passend für AC Challenge / Classic / Evolution / Excellence / Progress und Vertex Entspricht OEM Nr. 652.397	
	1746	Welle zu Drahtfang passend für AC 100 - 300 / 100 - 300D / 120 - 320 / 150 - 370 und 150 - 350FHSS Entspricht OEM Nr. 326.494	
	1749	Stopfen passend für AC 120 - 320 / 150 - 370 / 150 - 350FHSS und Sprint Entspricht OEM Nr. 361.934	
	1752	Sicherungsring 8 x 0,8 mm 1.4043 / X-40Cr13 passend für AC 100 - 300D / 120 - 320 / 150 - 350FHSS / 170 - 370 und Sprint Entspricht OEM Nr. 664.377	
	1754	Zylinderschraube M 4 x 6 mm St A4 DIN 912 passend für AC 150 - 350FHSS / Evolution / Progress und Vertex Entspricht OEM Nr. 639.867	
	1755	Gewindestift M 3 x 4 mm St A4 DIN 913 passend für AC 150 - 350FHSS / Evolution / Progress und Vertex Entspricht OEM Nr. 952.837	
	1758	Filterhalter 0,7 x 30 mm passend für AC Evolution / Progress und Vertex Entspricht OEM Nr. 448.104	
	1716	Kompletter Deckel Inox 55 x 55 x 11,4 mm passend für AC Classic / Evolution Entspricht OEM Nr. 834.664	
	1717	Deckel Inox 50 x 50 x 11 mm passend für AC Challenge / Classic / Evolution / Excellence / Progress und Vertex Entspricht OEM Nr. 201.712	

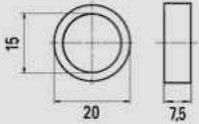

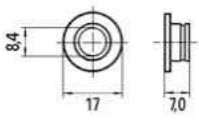







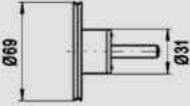

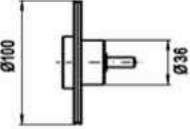

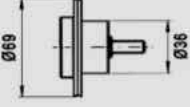

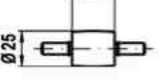

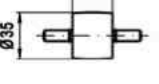

Welo Verschleisssteile passend zu Agie - Maschinen

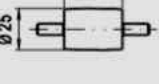
Allgemeine Verschleiss- und Ersatzteile

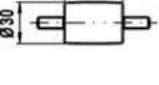
	Art. Nr.	Bezeichnung	
	1718	Kompletter Deckel passend für AC Classic / Evolution Entspricht OEM Nr. 436.214	
	1721	Scheibe Inox d= 11,4 x 3,1 x D= 18 mm passend für AC Classic / Evolution Entspricht OEM Nr. 258.433	
	1723	Schutz d= 9,0 x M 22 x 0,5 mm passend für AC Challenge / Classic / Evolution / und Excellence Entspricht OEM Nr. 201.702	
	1725	Einlass für Drahtschneider passend für AC Challenge / Classic / Evolution / und Excellence Entspricht OEM Nr. 836.304	
	1486	Spülgehäuse unten passend für AC Challenge / Classic / Evolution / Excellence und Progress Entspricht OEM-Nr. 836.284	
	1487	Spülgehäuse oben passend für AC Challenge / Classic / Evolution / Excellence und Progress Entspricht OEM-Nr. 836.274	
	1737	Gasdruckzylinder Frontklappe passend für AC EDM Entspricht OEM Nr. 689.207	
	1493	Schutz passend für AC Challenge / Classic / Evolution / Excellence / Progress und Vertex Entspricht OEM-Nr. 155.772	
	1766	Zwischenstück Inox Entspricht OEM-Nr. 848.164	
	1767	Kunststoff Büchse Entspricht OEM-Nr. 835.984	











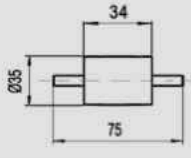

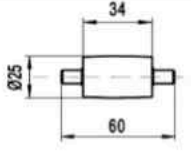

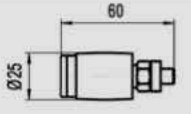

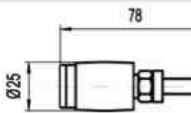

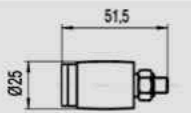

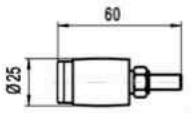
Welo Verschleissteile passend zu Agie - Maschinen

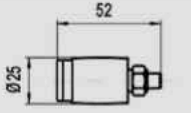
Rollen

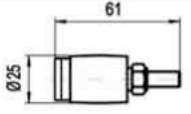
	Art. Nr.	Bezeichnung	
	1036	Umlenkrolle Entspricht OEM-Nr. 266.414	
	1037	Umlenkrolle Entspricht OEM-Nr. 243.904	
	1074	Umlenkrolle Entspricht OEM-Nr. 327.204	
	1124	Rolle zu Drahtfang Entspricht OEM-Nr. 323.324	
	1125	Rolle zu Drahtfang Entspricht OEM-Nr. 323.334	
	1126	Rolle zu Drahtfang Entspricht OEM-Nr. 323.344	
	1270	Rolle zu Drahtfang Entspricht OEM-Nr. 418.074	
	1271	Rolle zu Drahtfang Entspricht OEM-Nr. 418.094	
	1272	Rolle zu Drahtfang Entspricht OEM-Nr. 418.114	
	1302	Rolle 2° zu Drahtfang Entspricht OEM-Nr. 418.754	

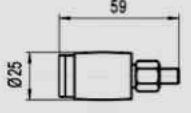
Welo Verschleissteile passend zu Agie - Maschinen

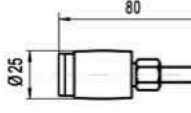
Rollen

	Art. Nr.	Bezeichnung	
	1303	Rolle komplett zu Drahtfang Entspricht OEM-Nr. 432.274 / 590432274 oder OEM-Nr. 432.454	
	1304	Rolle komplett zu Drahtfang Entspricht OEM-Nr. 432.284 / 590432284	
	1127	Umlenkrolle komplett Entspricht OEM-Nr. 323.354	
	1131	Umlenkrolle komplett Entspricht OEM-Nr. 338.474	
	1273	Umlenkrolle 2° komplett Entspricht OEM-Nr. 408.034	
	1274	Umlenkrolle 2° komplett Entspricht OEM-Nr. 408.044	
	1286	Umlenkrolle komplett Entspricht OEM-Nr. 418.144	
	1287	Umlenkrolle komplett Entspricht OEM-Nr. 418.154	
	1275	Umlenkrolle 2° komplett Entspricht OEM-Nr. 418.124 / 590418124	
	1276	Umlenkrolle 2° komplett Entspricht OEM-Nr. 418.134 / 590418134	

Welo Verschleissteile passend zu Agie - Maschinen

Rollen

Zeichnung	Art. Nr.	Bezeichnung	Foto
	1277	Umlenkrolle komplett Entspricht OEM-Nr. 418.654	
	1278	Umlenkrolle 4° komplett Entspricht OEM-Nr. 418.584	
	1279	Umlenkrolle 2° komplett Entspricht OEM-Nr. 418.634	
	1280	Umlenkrolle 2° komplett Entspricht OEM-Nr. 418.644	
	1281	Umlenkrolle 2° komplett Entspricht OEM-Nr. 418.704	
	1282	Umlenkrolle 2° komplett Entspricht OEM-Nr. 426.754	
	1283	Umlenkrolle 2° komplett Entspricht OEM-Nr. 424.754	
	1361	Rolle Entspricht OEM-Nr. 326.924	
	1284	Umlenkrolle 2° komplett Entspricht OEM-Nr. 418.274	
	1362	Umlenkrolle komplett Entspricht OEM-Nr. 221.573	







Welo Verschleissteile passend zu Agie - Maschinen

Rollen

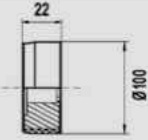
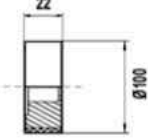
	Art. Nr.	Bezeichnung	
	1285	Umlenkrolle 2° komplett Entspricht OEM-Nr. 418.284	
	1363	Umlenkrolle komplett Entspricht OEM-Nr. 221.583	
	1128	Laufrolle 2° komplett Entspricht OEM-Nr. 323.364	
	1129	Laufrolle 4° komplett Entspricht OEM-Nr. 323.374	
	1147	Laufrolle komplett Entspricht OEM-Nr. 351.854	
	1130	Laufrolle komplett Entspricht OEM-Nr. 323.384	
	1143	Laufrolle komplett Entspricht OEM-Nr. 351.864	
	1144	Laufrolle komplett Entspricht OEM-Nr. 351.884	
	1145	Laufrolle komplett Entspricht OEM-Nr. 351.874	
	1146	Laufrolle 2° komplett Entspricht OEM-Nr. 352.584	

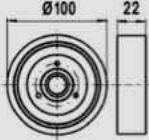
Welo Verschleissteile passend zu Agie - Maschinen

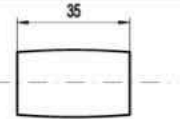
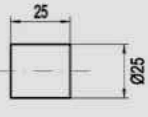
Rollen

	Art. Nr.	Bezeichnung	
	1100	Getriebenes Rad mit Phase passend für AC - Maschinen Entspricht OEM-Nr. 180.513	
	1101	Getriebenes Rad passend für DEM - Serie Entspricht OEM-Nr. 142.413	
	1033	Saphirrolle Entspricht OEM-Nr. 291.134	
	1288	Kunststoff - Umlenkrolle passend für DEM - Serie Entspricht OEM-Nr. 271.664	
	1327	Anpressrolle hartverchromt Passende Lager: Welo Art.-Nr. 1328 Entspricht OEM-Nr. 217.024	
	1748	Rolle passend für AC 120 - 320 / 150 - 370 / 150 - 350FHSS und Sprint Entspricht OEM Nr. 326.344	
	1750	Rolle passend für AC 120 - 320 / 150 - 370 / 150 - 350FHSS und Sprint Entspricht OEM Nr. 368.874	
	1751	Rolle passend für AC 120 - 320 / 150 - 350FHSS und 170 - 370 Entspricht OEM Nr. 418.264	
	1747	Rolle passend für AC 120 - 320 / 150 - 370 / 150 - 350FHSS und Sprint Entspricht OEM Nr. 404.814	
	1753	Rollenset zu Drahtfang Univ 20n R passend für AC 150 - 350FHSS und 170 - 370 Entspricht OEM Nr. 837.904	

Welo Verschleissteile passend zu Agie - Maschinen

Rollen

	Art. Nr.	Bezeichnung	
	1499	Drahtabzugsrolle gehärtet passend für AC Classic / Evolution Entspricht OEM-Nr. 239.003	
	1301	Rolle passend für HSS - Maschinen Entspricht OEM-Nr. 387.964	
	1078	Druckrolle komplett zu Bremse Entspricht OEM-Nr. 338.454	
	1078-1	Druckrolle komplett zu Bremse neue Ausführung Entspricht OEM-Nr. 338.454	
	1251	Druckrolle komplett zu Bremse Entspricht OEM-Nr. 418.774	
	1759	Druckrolle komplett zu Bremse Entspricht OEM-Nr. 035.394	
	1761	Drahtzugrollen für Drahtdurchmesser D= 0,03 - 0,33 mm (1 Satz = 2 Stück) Entspricht OEM-Nr. 002.254 / 590002254	

Welo Verschleissteile passend zu Agie - Maschinen

Rollen

Wegweiche

Art. Nr. Bezeichnung

1313 Führungsrolle
komplett
Entspricht OEM-Nr. 238.633
Auf Wunsch können alle Teile einzeln geliefert werden

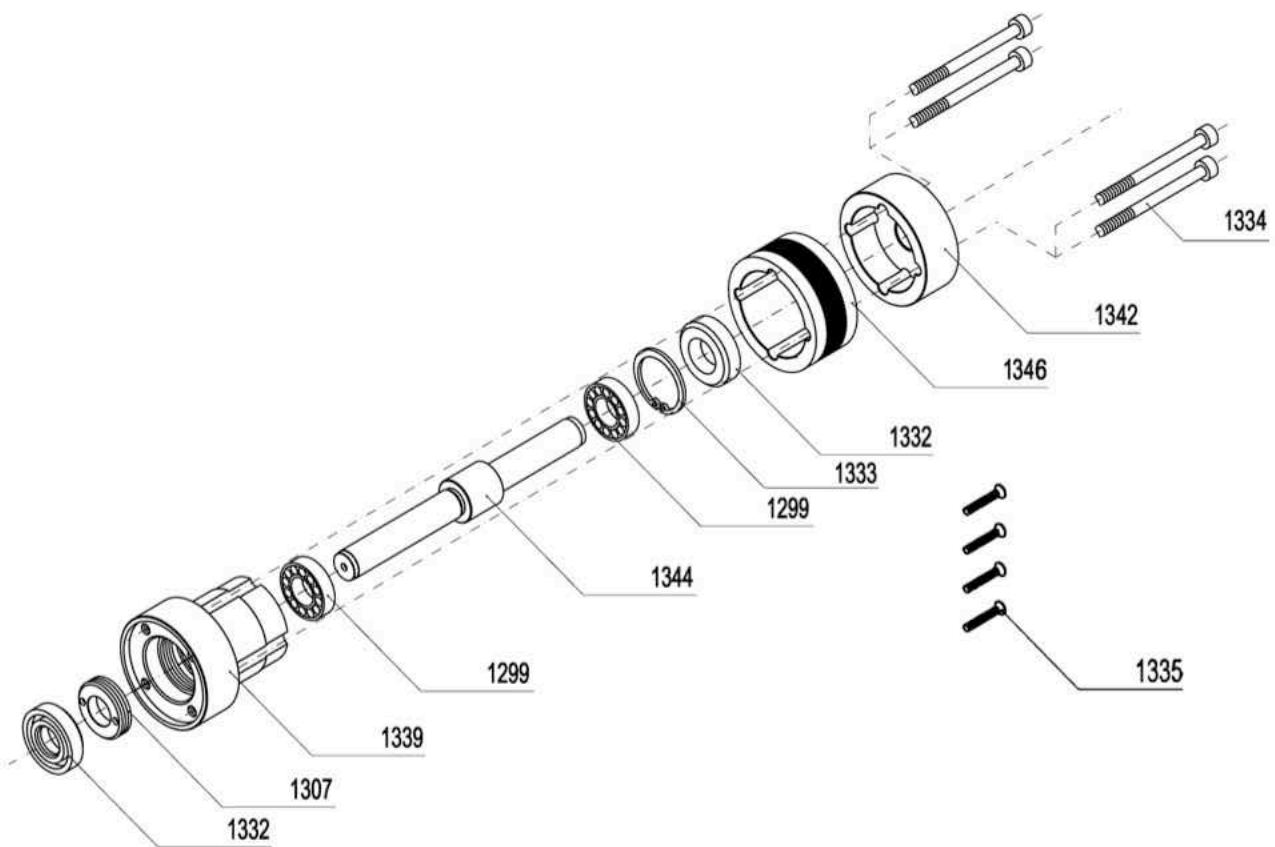
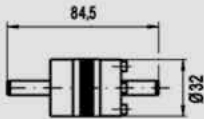



Art. Nr. Bezeichnung

- | | |
|-------------|--------------------------|
| 1332 | Wellendichtring |
| 1307 | Druckschraube |
| 1339 | Kunststoffrolle |
| 1299 | Kugellager |
| 1344 | Welle |
| 1333 | Sicherungsring |
| 1346 | Rolle diamantbeschichtet |
| 1342 | Kunststoffdeckel |
| 1334 | Zylinderkopfschraube |
| 1335 | Senkkopfschraube |

Welo Verschleissteile passend zu Agie - Maschinen

Rollen

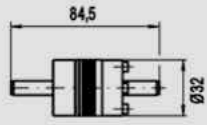
Art. Nr.	Bezeichnung
1314	Führungsrolle komplett Entspricht OEM-Nr. 238.643 Auf Wunsch können alle Teile einzeln geliefert werden

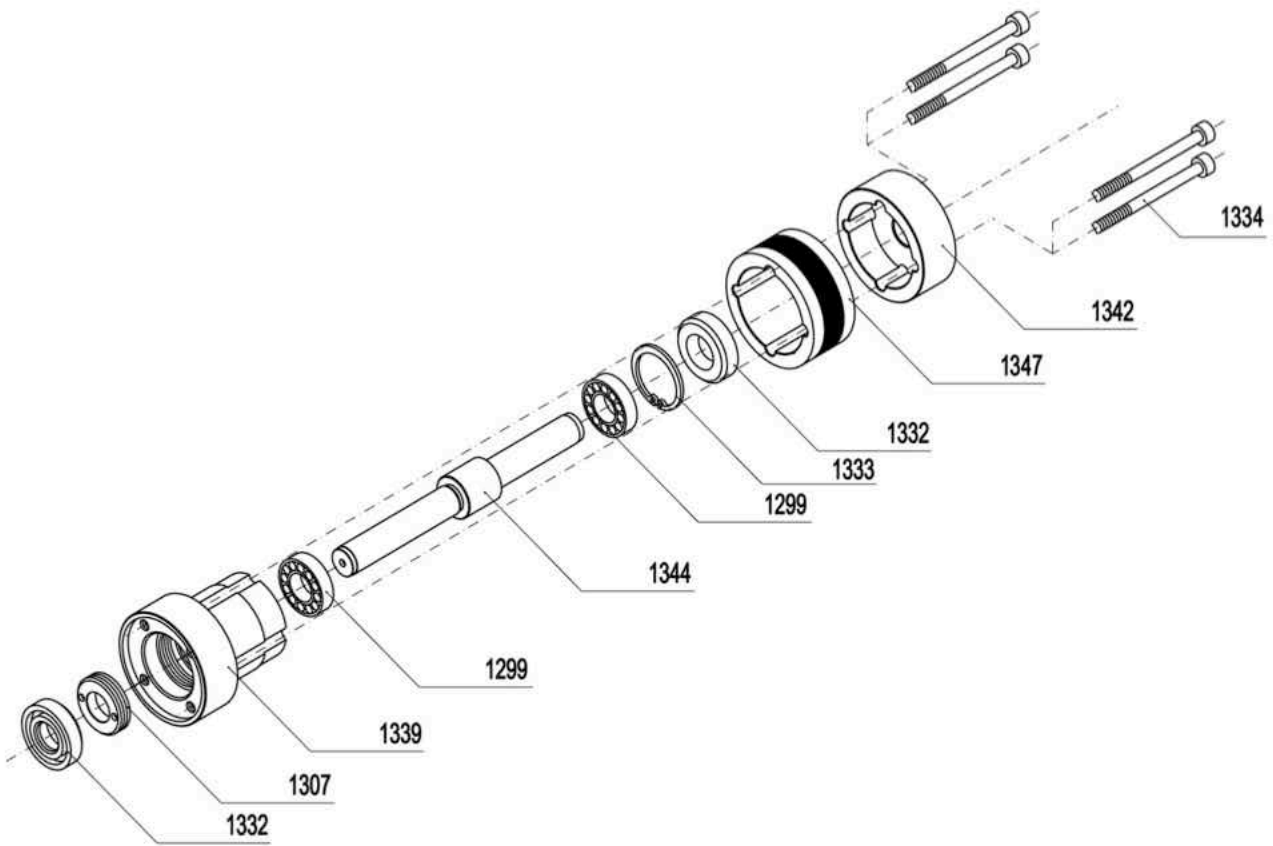



Art. Nr.	Bezeichnung
1332	Wellendichtring
1307	Druckschraube
1339	Kunststoffrolle
1299	Kugellager
1344	Welle
1333	Sicherungsring
1347	Rolle diamantbeschichtet
1342	Kunststoffdeckel
1334	Zylinderkopfschraube

Welo Verschleissteile passend zu Agie - Maschinen

Rollen

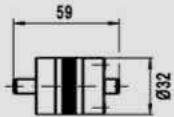
Wegweiser



Art. Nr. Bezeichnung

1315 Drahtzugsrolle
komplett
Entspricht OEM-Nr. 418.954
Auf Wunsch können alle Teile einzeln geliefert werden

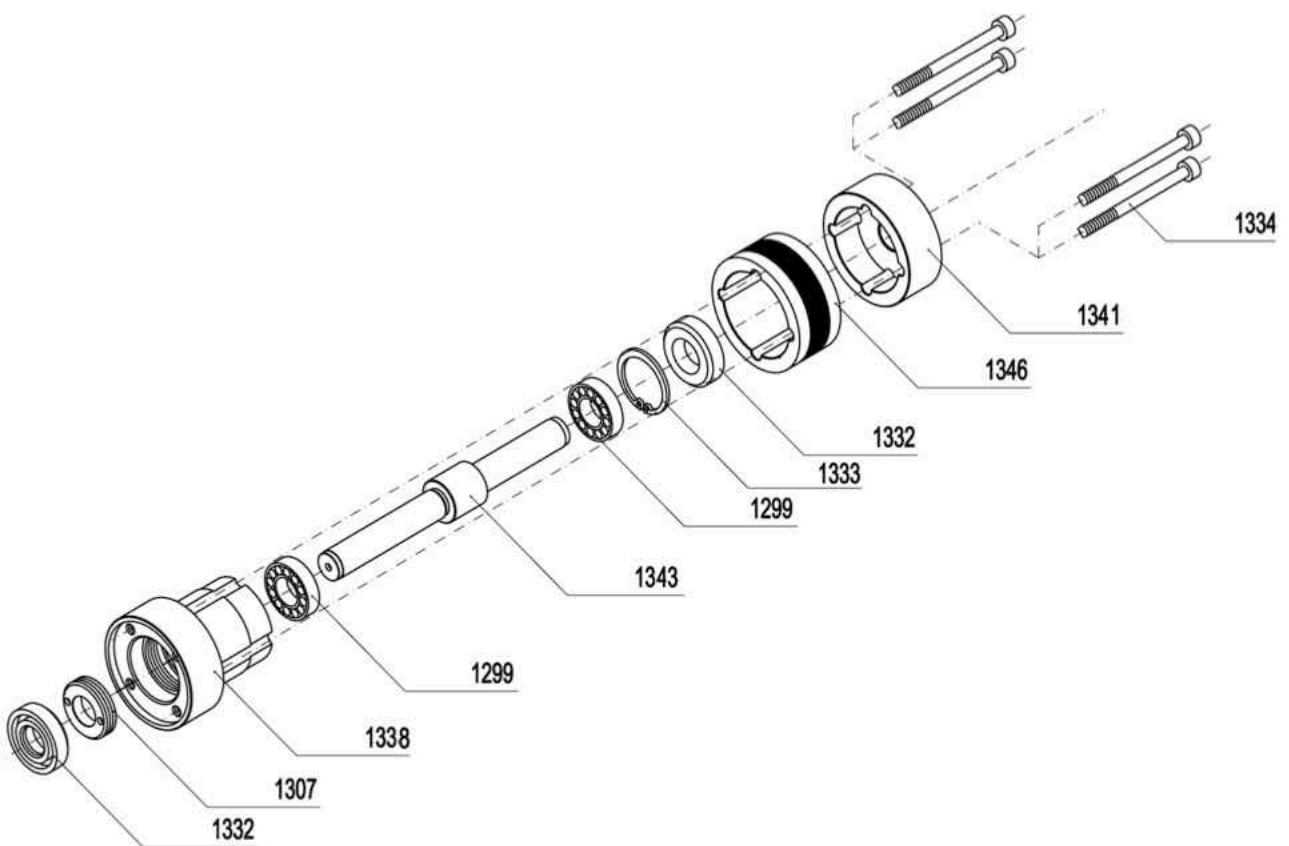

Art. Nr. Bezeichnung

1332	Wellendichtring
1307	Druckschraube
1338	Kunststoffrolle
1299	Kugellager
1343	Welle
1333	Sicherungsring
1346	Rolle diamantbeschichtet
1341	Kunststoffdeckel
1334	Zylinderkopfschraube

Welo Verschleissteile passend zu Agie - Maschinen

Rollen

Wegweiser

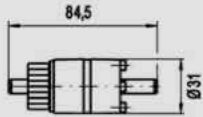



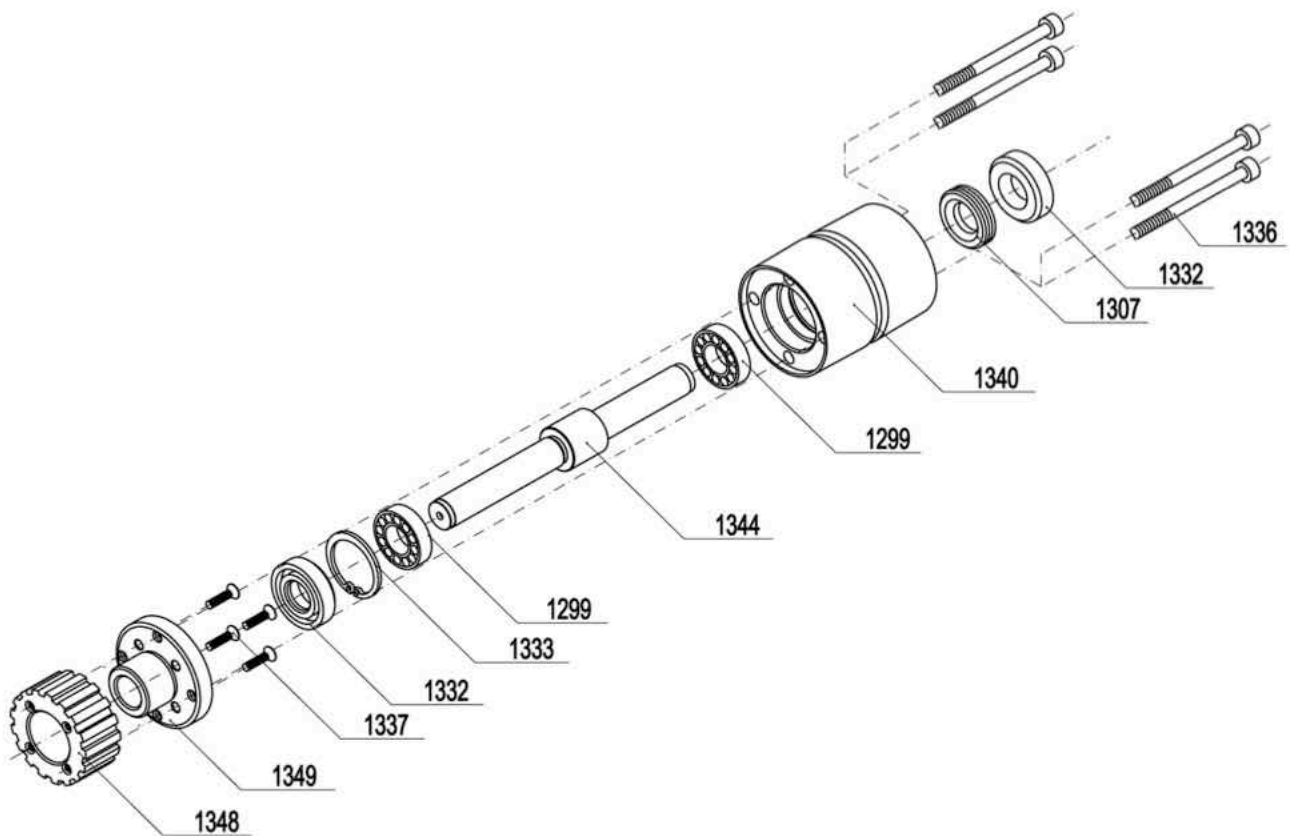

Art. Nr.	Bezeichnung
1316	Antriebsrolle komplett Entspricht OEM-Nr. 418.944 Auf Wunsch können alle Teile einzeln geliefert werden

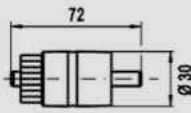

Art. Nr.	Bezeichnung
1348	Zahnriemenrad
1349	Adapter
1337	Senkkopfschraube
1332	Wellendichtring
1333	Sicherungsring
1299	Kugellager
1344	Welle
1340	Kunststoffrolle
1307	Druckschraube
1336	Zylinderkopfschraube

Welo Verschleisssteile passend zu Agie - Maschinen

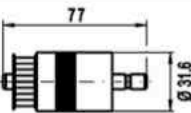
Rollen

	Art. Nr.	Bezeichnung	
	1317	Antriebsrolle komplett Entspricht OEM-Nr. 241.233 / 590241233 Rolle kann nicht in Einzelteilen geliefert werden Rolle ist komplett vergossen	
	1318	Führungsrolle getrieben Entspricht OEM-Nr. 241.253 / 251.553 / 590241253 Rolle kann nicht in Einzelteilen geliefert werden Rolle ist komplett vergossen	

Welo Verschleissteile passend zu Agie - Maschinen

Massekabel passend zu AC Sprint HSS

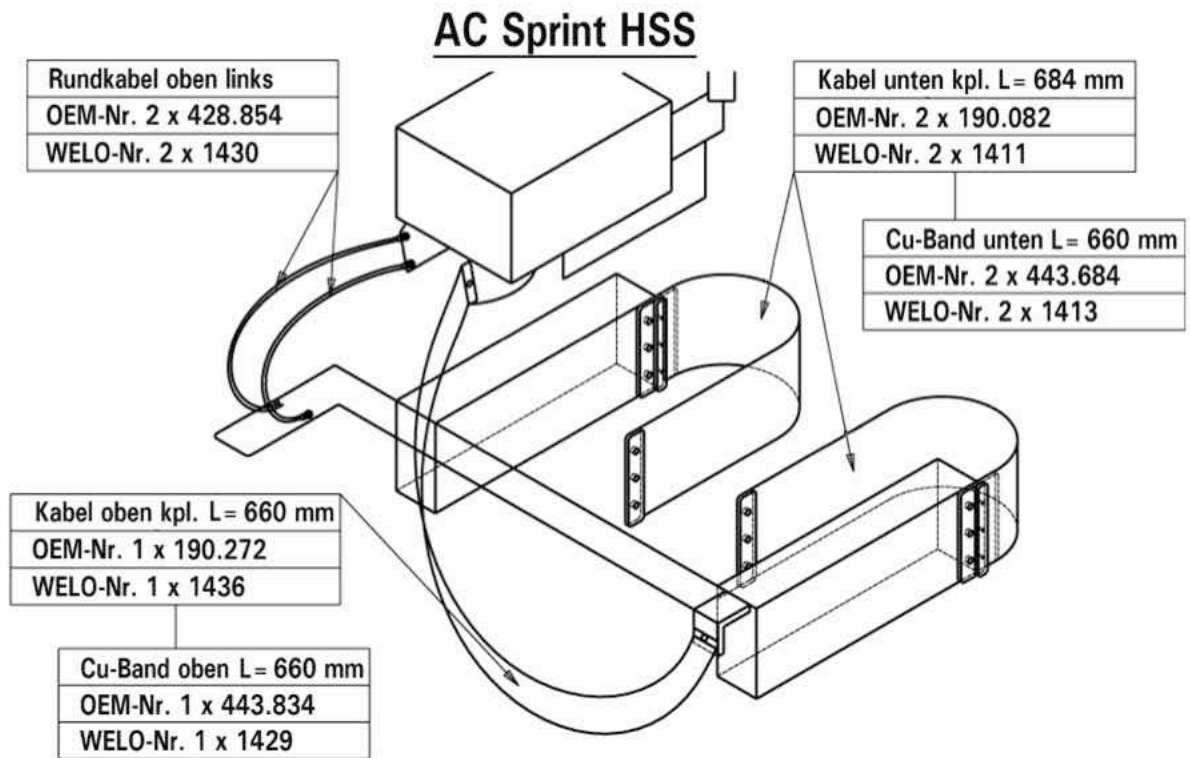

Art. Nr.	Bezeichnung
----------	-------------

Ersatzteile zu Kabel
komplett nach Umrüstung

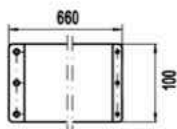

1413	Kupfer - Band unten L= 660 mm Entspricht OEM-Nr. 443.684
-------------	---



1421	Klemm - Platte
-------------	----------------

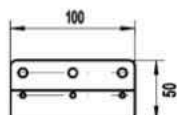









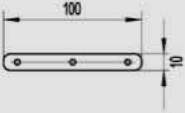



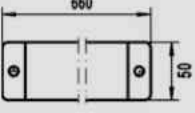

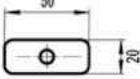

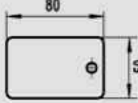
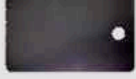
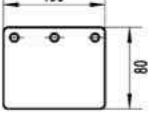
1419	Abgekröpfte Platte
-------------	--------------------





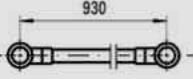



Welo Verschleissteile passend zu Agie - Maschinen

Massekabel passend zu AC Sprint HSS

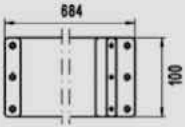
	Art. Nr.	Bezeichnung	
	1420	Klemm - Leiste	
	1418	Linsenkopfschraube M3 x 5 mm zum Befestigen für WELO-Nr. 1419 / 1420 / 1413	
	1429	Kupfer - Band oben L= 660 mm Entspricht OEM-Nr. 443.834	
	1415	Klemm - Platte Entspricht OEM-Nr. 441.904	
	1414	Federplatte Entspricht OEM-Nr. 443.764	
	1422	Federplatte	
	1416	Linsenkopfschraube M6 x 10 mm zum Befestigen für WELO-Nr. 1419 / 1421 / 1413 / 1429 / 1415 / 1414 / 1422 Entspricht OEM-Nr. 659.557	
	1417	Unterlagscheibe VA d= 6,4 mm für WELO-Nr. 1416	
	1430	Rundkabel oben links Entspricht OEM-Nr. 428.854	

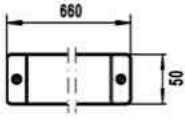
Welo Verschleissteile passend zu Agie - Maschinen

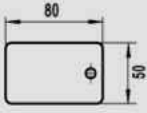
Massekabel passend zu AC Sprint HSS

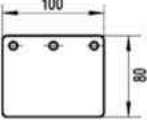
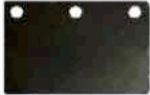
	Art. Nr.	Bezeichnung	
	1411	Kabel unten komplett L= 684 mm montiert bestehend aus WELO-Nr. je 1 x 1413 / 1419 / 1420 / 1421 je 3 x 1418 je 6 x 1416 / 1417 Entspricht OEM-Nr. 190.082	
	1436	Kabel oben komplett L= 660 mm bestehend aus WELO-Nr. je 1 x 1429 je 2 x 1415 / 1416 / 1417 Entspricht OEM-Nr. 190.272	
	1414	Federplatte Entspricht OEM-Nr. 443.764	
	1422	Federplatte	

Welo Verschleissteile passend zu Agie - Maschinen

Massekabel passend zu AC 1X0 HSS

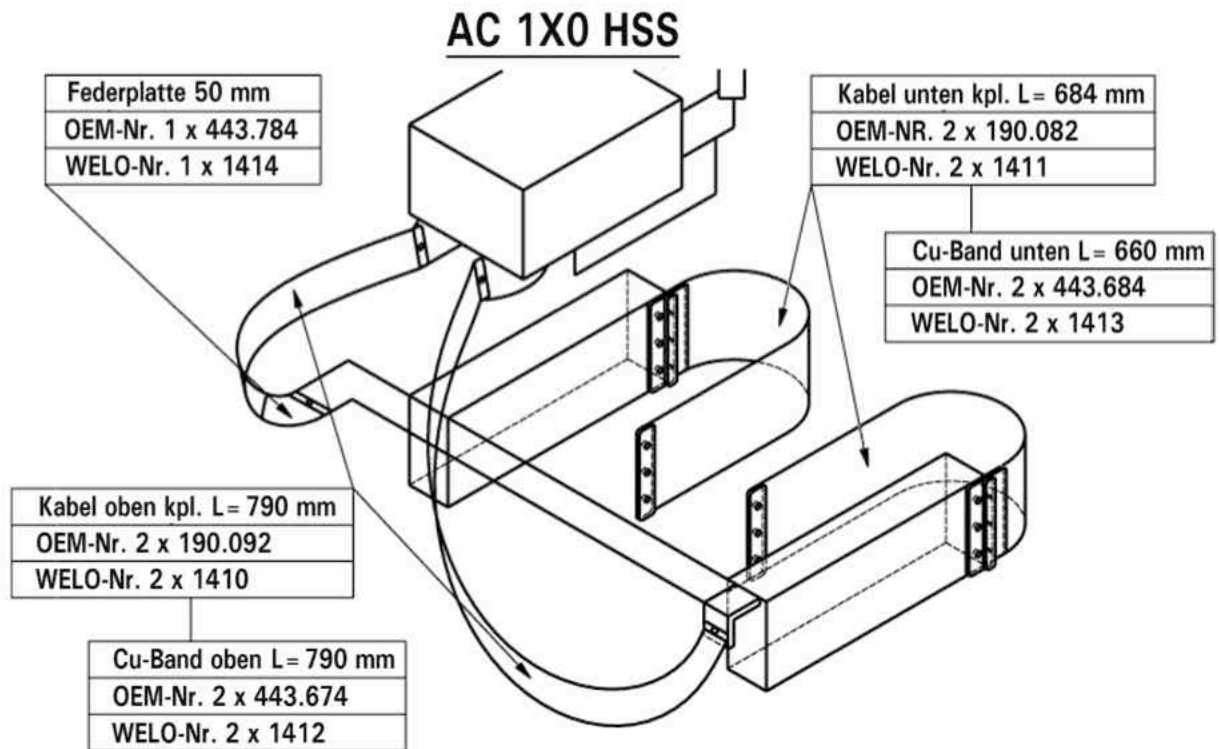







Art. Nr. Bezeichnung

Art. Nr.	Bezeichnung	
	Ersatzteile zu Kabel komplett nach Umrüstung	
	1413 Kupfer - Band unten L= 660 mm Entspricht OEM-Nr. 443.684	
	1421 Klemm - Platte	
	1419 Abgekröpfte Platte	

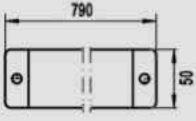

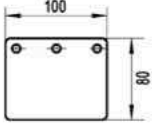



Welo Verschleissteile passend zu Agie - Maschinen

Massekabel passend zu AC 1X0 HSS

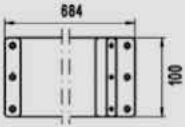
	Art. Nr.	Bezeichnung	
	1420	Klemm - Leiste	
	1418	Linsenkopfschraube M3 x 5 mm zum Befestigen für WELO-Nr. 1419 / 1420 / 1413	
	1412	Kupfer - Band oben L= 790 mm Entspricht OEM-Nr. 443.674	
	1415	Klemm - Platte Entspricht OEM-Nr. 441.904	
	1414	Federplatte Entspricht OEM-Nr. 443.764	
	1422	Federplatte	
	1416	Linsenkopfschraube M6 x 10 mm zum Befestigen für WELO-Nr. 1419 / 1421 / 1413 / 1412 / 1415 / 1414 / 1422 Entspricht OEM-Nr. 659.557	
	1417	Unterlagscheibe VA d= 6,4 mm für WELO-Nr. 1416	

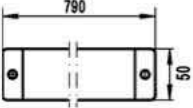
Welo Verschleissteile passend zu Agie - Maschinen

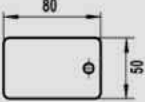
Massekabel passend zu AC 1X0 HSS

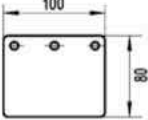
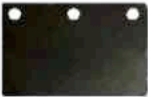
	Art. Nr.	Bezeichnung	
	1411	Kabel unten komplett L= 684 mm montiert bestehend aus WELO-Nr. je 1 x 1413 / 1419 / 1420 / 1421 je 3 x 1418 je 6 x 1416 / 1417 Entspricht OEM-Nr. 190.082	
	1410	Kabel oben komplett L= 790 mm bestehend aus WELO-Nr. je 1 x 1412 je 2 x 1415 / 1416 / 1417 Entspricht OEM-Nr. 190.092	
	1414	Federplatte Entspricht OEM-Nr. 443.764	
	1422	Federplatte	

Welo Verschleissteile passend zu Agie - Maschinen

Massekabel passend zu AC 2X0 HSS

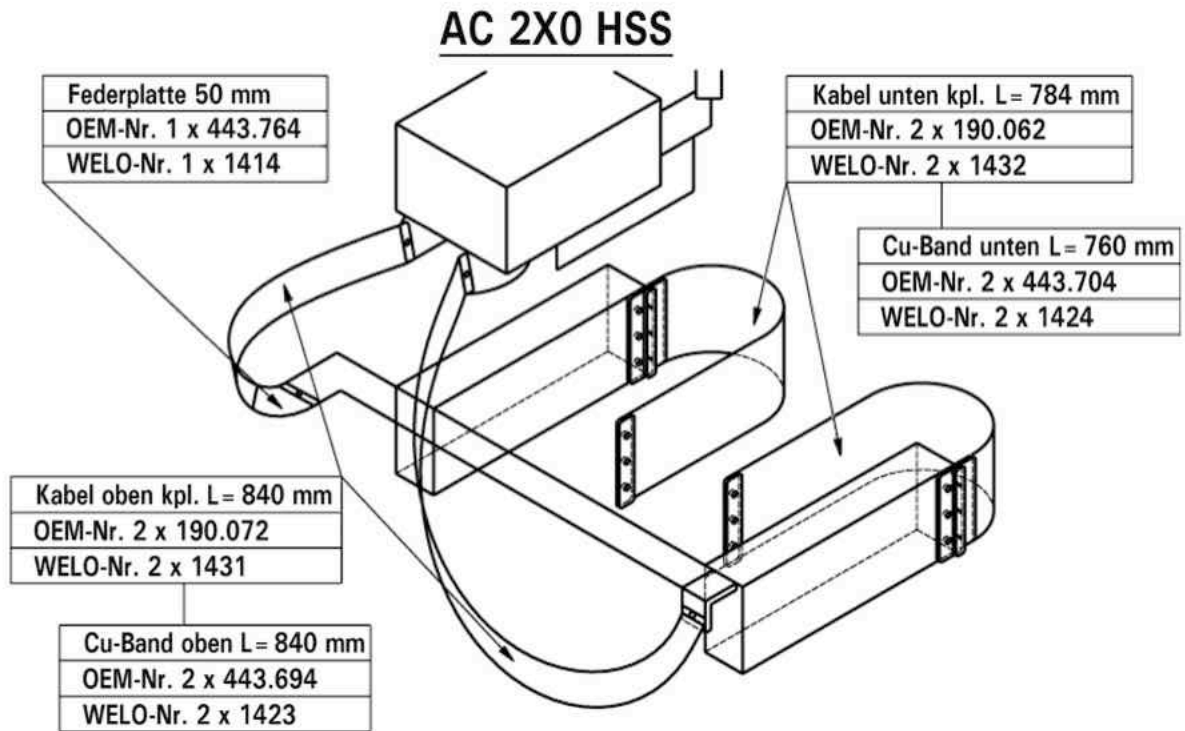

Art. Nr.	Bezeichnung
	Ersatzteile zu Kabel komplett nach Umrüstung
	1424 Kupfer - Band unten L = 760 mm Entspricht OEM-Nr. 443.704
	1421 Klemm - Platte
	1419 Abgekröpfte Platte

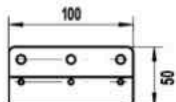
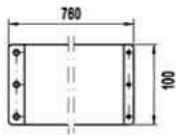







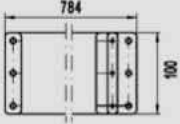

Welo Verschleissteile passend zu Agie - Maschinen

Massekabel passend zu AC 2X0 HSS

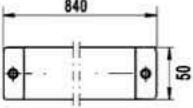
	Art. Nr.	Bezeichnung	
	1420	Klemm - Leiste	
	1418	Linsenkopfschraube M3 x 5 mm zum Befestigen für WELO-Nr. 1419 / 1420 / 1424	
	1423	Kupfer - Band oben L= 840 mm Entspricht OEM-Nr. 443.694	
	1415	Klemm - Platte Entspricht OEM-Nr. 441.904	
	1414	Federplatte Entspricht OEM-Nr. 443.764	
	1422	Federplatte	
	1416	Linsenkopfschraube M6 x 10 mm zum Befestigen für WELO-Nr. 1419 / 1421 / 1424 / 1423 / 1415 / 1414 / 1422 Entspricht OEM-Nr. 659.557	
	1417	Unterlagscheibe VA d= 6,4 mm für WELO-Nr. 1416	

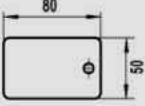
Welo Verschleissteile passend zu Agie - Maschinen

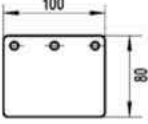
Massekabel passend zu AC 2X0 HSS

	Art. Nr.	Bezeichnung	
	1432	Kabel unten komplett L= 784 mm montiert bestehend aus WELO-Nr. je 1 x 1424 / 1419 / 1420 / 1421 je 3 x 1418 je 6 x 1416 / 1417 Entspricht OEM-Nr. 190.062	
	1431	Kabel oben komplett L= 840 mm bestehend aus WELO-Nr. je 1 x 1423 je 2 x 1415 / 1416 / 1417 Entspricht OEM-Nr. 190.072	
	1414	Federplatte Entspricht OEM-Nr. 443.764	
	1422	Federplatte	

Welo Verschleissteile passend zu Agie - Maschinen

Massekabel passend zu AC 3X0 HSS

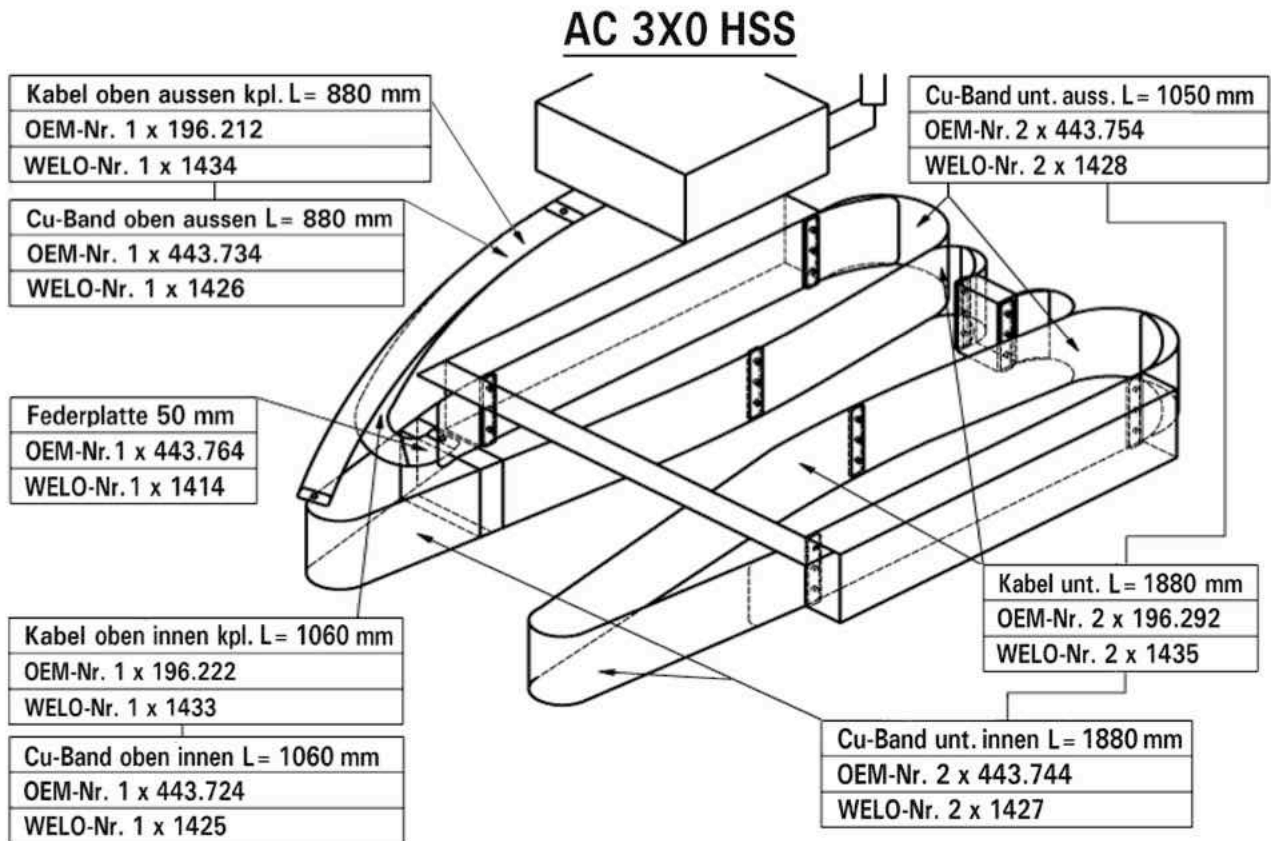

Art. Nr. Bezeichnung

Art. Nr.	Bezeichnung	
	Ersatzteile zu Kabel komplett nach Umrüstung	
	1427 Kupfer - Band unten innen L= 1880 mm Entspricht OEM-Nr. 443.744	
	1428 Kupfer - Band unten aussen L= 1050 mm Entspricht OEM-Nr. 443.754	
	1421 Klemm - Platte	

Welo Verschleissteile passend zu Agie - Maschinen

Massekabel passend zu AC 3X0 HSS

Welo Zeichnung	Art. Nr.	Bezeichnung	Foto
	1426	Kupfer - Band oben aussen L= 880 mm Entspricht OEM-Nr. 443.734	
	1425	Kupfer - Band oben innen L= 1060 mm Entspricht OEM-Nr. 443.724	
	1415	Klemm - Platte Entspricht OEM-Nr. 441.904	
	1416	Linsenkopfschraube M6 x 10 mm zum Befestigen für WELO-Nr. 1421 / 1427 / 1428 / 1426 / 1425 / 1415 / 1414 / 1422 Entspricht OEM-Nr. 659.557	
	1417	Unterlagscheibe VA d= 6,4 mm für WELO-Nr. 1416	
	1414	Federplatte Entspricht OEM-Nr. 443.764	
	1422	Federplatte	
	1435	Kabel unten komplett L= 1880 mm bestehend aus WELO-Nr. je 1 x 1427 / 1428 je 4 x 1421 je 12 x 1416 / 1417 Entspricht OEM-Nr. 196.292	
	1434	Kabel oben aussen komplett L= 880 mm bestehend aus WELO-Nr. je 1 x 1426 je 2 x 1415 / 1416 / 1417 Entspricht OEM-Nr. 196.212	

Welo Verschleissteile passend zu Agie - Maschinen

Massekabel passend zu AC 3X0 HSS

	Art. Nr.	Bezeichnung	
	1433	Kabel oben innen komplett L= 1060 mm bestehend aus WELO-Nr. je 1 x 1425 je 2 x 1415 / 1416 / 1417 Entspricht OEM-Nr. 196.222	
	1414	Federplatte Entspricht OEM-Nr. 443.764	
	1422	Federplatte	

Welo Verschleisssteile passend zu Agie - Maschinen

O - Ringe

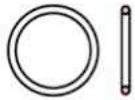

Art. Nr. Bezeichnung

Art. Nr.	Bezeichnung
	O - Ringe
1500	Entspricht OEM-Nr. 831.867
1501	Entspricht OEM-Nr. 650.887
1502	Entspricht OEM-Nr. 645.537
1503	Entspricht OEM-Nr. 645.517
1504	Entspricht OEM-Nr. 645.507
1505	Entspricht OEM-Nr. 832.127
1506	Entspricht OEM-Nr. 645.527
1507	Entspricht OEM-Nr. 646.737
1508	Entspricht OEM-Nr. 654.507
1509	Entspricht OEM-Nr. 830.547
1510	Entspricht OEM-Nr. 830.457
1511	Entspricht OEM-Nr. 830.527
1512	Entspricht OEM-Nr. 831.057
1513	Entspricht OEM-Nr. 831.317
1514	Entspricht OEM-Nr. 674.227
1515	Entspricht OEM-Nr. 831.817
1516	Entspricht OEM-Nr. 601.467
1517	Entspricht OEM-Nr. 601.507
1518	Entspricht OEM-Nr. 601.567
1519	Entspricht OEM-Nr. 603.047
1520	Entspricht OEM-Nr. 607.577
1521	Entspricht OEM-Nr. 607.787
1522	Entspricht OEM-Nr. 615.567
1523	Entspricht OEM-Nr. 619.037
1524	Entspricht OEM-Nr. 620.147
1525	Entspricht OEM-Nr. 623.577
1526	Entspricht OEM-Nr. 625.277
1527	Entspricht OEM-Nr. 625.537
1528	Entspricht OEM-Nr. 639.677
1529	Entspricht OEM-Nr. 641.997
1530	Entspricht OEM-Nr. 651.117
1531	Entspricht OEM-Nr. 654.547
1532	Entspricht OEM-Nr. 654.877
1533	Entspricht OEM-Nr. 655.267
1534	Entspricht OEM-Nr. 656.527
1535	Entspricht OEM-Nr. 658.227
1536	Entspricht OEM-Nr. 659.647
1537	Entspricht OEM-Nr. 659.657
1538	Entspricht OEM-Nr. 663.807
1539	Entspricht OEM-Nr. 663.817



Welo Verschleisssteile passend zu Agie - Maschinen

O - Ringe

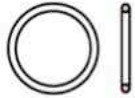

Art. Nr. Bezeichnung

Art. Nr.	Bezeichnung
	O - Ringe
1540	Entspricht OEM-Nr. 663.837
1541	Entspricht OEM-Nr. 664.807
1542	Entspricht OEM-Nr. 664.827
1543	Entspricht OEM-Nr. 664.837
1544	Entspricht OEM-Nr. 664.847
1545	Entspricht OEM-Nr. 664.857
1546	Entspricht OEM-Nr. 666.707
1547	Entspricht OEM-Nr. 666.717
1548	Entspricht OEM-Nr. 674.197
1549	Entspricht OEM-Nr. 674.207
1550	Entspricht OEM-Nr. 674.217
1551	Entspricht OEM-Nr. 830.117
1552	Entspricht OEM-Nr. 830.127
1553	Entspricht OEM-Nr. 830.307
1554	Entspricht OEM-Nr. 830.467
1555	Entspricht OEM-Nr. 830.487
1556	Entspricht OEM-Nr. 830.537
1557	Entspricht OEM-Nr. 830.577
1558	Entspricht OEM-Nr. 830.697
1559	Entspricht OEM-Nr. 830.747
1560	Entspricht OEM-Nr. 830.757
1561	Entspricht OEM-Nr. 830.777
1562	Entspricht OEM-Nr. 830.787
1563	Entspricht OEM-Nr. 830.867
1564	Entspricht OEM-Nr. 830.877
1565	Entspricht OEM-Nr. 830.917
1566	Entspricht OEM-Nr. 830.927
1567	Entspricht OEM-Nr. 830.937
1568	Entspricht OEM-Nr. 830.987
1569	Entspricht OEM-Nr. 831.007
1570	Entspricht OEM-Nr. 831.117
1571	Entspricht OEM-Nr. 831.217
1572	Entspricht OEM-Nr. 831.227
1573	Entspricht OEM-Nr. 831.367
1574	Entspricht OEM-Nr. 831.417
1575	Entspricht OEM-Nr. 831.457
1576	Entspricht OEM-Nr. 831.487
1577	Entspricht OEM-Nr. 831.537
1578	Entspricht OEM-Nr. 831.587
1579	Entspricht OEM-Nr. 831.707



Welo Verschleissteile passend zu Agie - Maschinen

O - Ringe

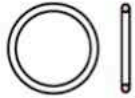

Art. Nr.	Bezeichnung
	O - Ringe
1580	Entspricht OEM-Nr. 831.727
1581	Entspricht OEM-Nr. 831.747
1582	Entspricht OEM-Nr. 831.797
1583	Entspricht OEM-Nr. 831.807
1584	Entspricht OEM-Nr. 831.827
1585	Entspricht OEM-Nr. 831.847
1586	Entspricht OEM-Nr. 832.017
1587	Entspricht OEM-Nr. 832.027
1588	Entspricht OEM-Nr. 832.147
1589	Entspricht OEM-Nr. 832.167
1590	Entspricht OEM-Nr. 832.247
1591	Entspricht OEM-Nr. 832.277
1592	Entspricht OEM-Nr. 674.237.3
1593	O - Ring D= 16,0 x 1,0 mm Nitril 75 passend für AC Challenge / Classic / Evolution / Excellence / Progress und Vertex Entspricht OEM Nr. 692.027
1594	O - Ring D= 12,0 x 3,0 mm Nitril 75 passend für AC Challenge / Classic / Evolution / Excellence / Progress und Vertex Entspricht OEM Nr. 692.647
1595	O - Ring D= 198 x 10 mm passend für AC 120 - 320 / 150 - 370 und 150 - 350FHSS Entspricht OEM Nr. 662.647
1596	O - Ring D= 3,8 x 1,5 mm passend für AC Challenge / Classic / Evolution / Excellence / Progress und Vertex Entspricht OEM Nr. 832.267
1597	O - Ring D= 2,3 x 1,5 mm passend für AC 150 - 350FHSS und 170 - 370 Entspricht OEM Nr. 688.797
1598	Kt O - Ring Nf - 775 D1= 6,3 D2= 0,5 mm Nbr passend für AC 150 - 350FHSS / 170 - 370 und Sprint Entspricht OEM Nr. 680.467













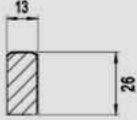

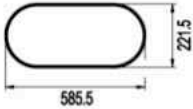

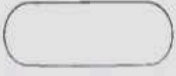

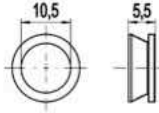

Welo Verschleissteile passend zu Agie - Maschinen

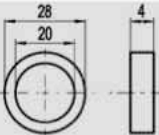
Schmierstoffe

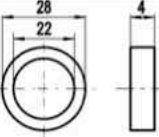
Art. Nr.	Bezeichnung	
1726	Fett Isoflex Topas AK50 1 kg Dose Entspricht OEM Nr. 006.018	
1727	Fett Centoplex CX 4 / 375 AU 1 kg Dose Entspricht OEM Nr. 151.308	
1730	Fett Microlube GBU - Y131 1 kg Dose passend für AC EDM (50 g = Entspricht OEM Nr. 012.948)	
1731	Fett Microlube GBU - Y131 50 g Tube passend für AC EDM Entspricht OEM Nr. 012.948	
1732	Fett Centoplex CX 4 - 375 AU 45 g Tube passend für AC EDM Entspricht OEM Nr. 132.028	
1733	Fett Isoflex AK50 45 g Tube passend für AC EDM Entspricht OEM Nr. 012.648	
1734	Fett Isoflex NBU15 50 g Tube passend für AC EDM Entspricht OEM Nr. 151.678	

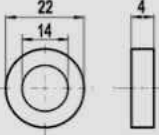

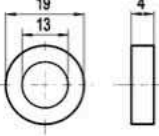



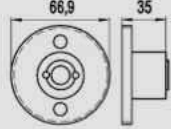

Welo Verschleissteile passend zu Agie - Maschinen

Dichtungen

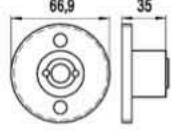
	Art. Nr.	Bezeichnung	
	1102	Moosgummi 26 x 13 mm Neopren für Tankdichtung in allen gewünschten Längen lieferbar Entspricht OEM-Nr. 025.796	
	1480	Beckenrückwand - Dichtung 221,5 x 5 x 585,5 mm passend für AC Challenge / Classic / Evolution / Excellence / Progress und Vertex Entspricht OEM-Nr. 000.234	
	1481	Beckenrückwand - Dichtung 221,5 x 5 x 735,5 mm passend für AC Challenge / Classic / Evolution / Excellence / Progress und Vertex Entspricht OEM-Nr. 000.244	
	1482	O - Ring zu Welo Art. Nr. 1480 passend für AC Challenge / Classic / Evolution / Excellence / Progress und Vertex Entspricht OEM-Nr. 694.057	
	1483	O - Ring zu Welo Art. Nr. 1481 passend für AC Challenge / Classic / Evolution / Excellence / Progress und Vertex Entspricht OEM-Nr. 694.397	
	1738	Dichtung V d= 10,5 W= 3 B2= 3,4 B= 5,5 mm passend für AC Challenge / Classic / Evolution / Excellence / Progress und Vertex Entspricht OEM Nr. 689.857	
	1739	Dichtung einlippig Typ G d= 20 D= 28 B= 4 mm passend für AC Challenge / Classic / Evolution / Excellence / Progress und Vertex Entspricht OEM Nr. 820.907	
	1740	Dichtung G d= 22 D= 28 B= 4 mm passend für AC Classic und Evolution Entspricht OEM Nr. 822.317	
	1741	Sicherheitsring d= 14 D= 22 B= 4 mm passend für AC 120 - 320 / 150 - 370 / 150 - 350FHSS und Sprint Entspricht OEM Nr. 667.627	
	1742	Sicherheitsring d= 13 D= 19 B= 4 mm passend für AC 120 - 320 / 150 - 370 / 150 - 350FHSS und Sprint Entspricht OEM Nr. 667.637	

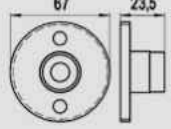
Welo Verschleissteile passend zu Agie - Maschinen

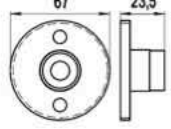
Zahnräder

	Art. Nr.	Bezeichnung	
	1712	Zahnrad Z= 61 D= 66,9 B= 35 mm passend für AC Classic / Evolution Entspricht OEM Nr. 239.643	
	1713	Zahnrad Z= 61 D.pl D= 66,9 B= 35 mm passend für AC Classic / Evolution Entspricht OEM Nr. 239.653	
	1714	Zahnrad Z= 61 D= 67 B= 23,5 mm passend für AC Challenge / Classic / Evolution / Excellence / Progress und Vertex Entspricht OEM Nr. 202.032	
	1715	Zahnrad Z= 61 D= 67 B= 23,5 mm passend für AC Challenge / Classic / Evolution / Excellence / Progress und Vertex Entspricht OEM Nr. 202.052	











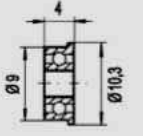

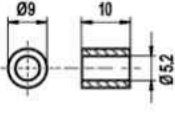

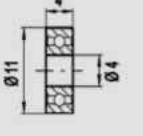

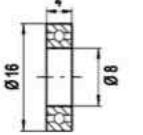

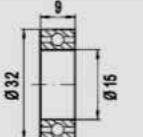
Welo Verschleissteile passend zu Agie - Maschinen

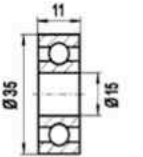
Federn

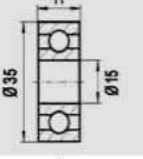
	Art. Nr.	Bezeichnung	
	1154	Feder zu Drahtfang Entspricht OEM-Nr. 326.324	
	1155	Druckfeder zu Hartmetall Messer Entspricht OEM-Nr. 645.567	
	1359	Zugfeder Entspricht OEM-Nr. 337.824	
	1364	Druckfeder Entspricht OEM-Nr. 395.044	
	1743	Torsionsfeder zu Bremse 0,9 Ac 8,5 x 10,5 mm passend für AC EDM Entspricht OEM Nr. 326.944	
	1744	Feder passend für AC 150 - 350FHS / S / 100 - 300D / 170 - 370 / Evolution / Progress / Sprint und Vertex Entspricht OEM Nr. 395.354	

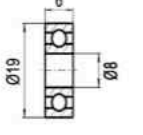

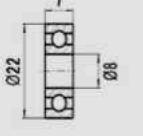







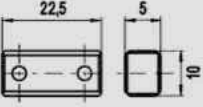

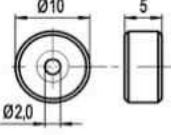

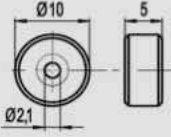

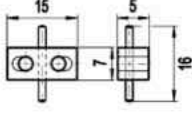

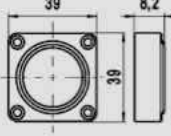

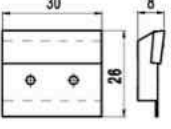
Welo Verschleissteile passend zu Agie - Maschinen

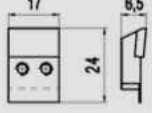
Lager

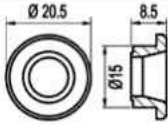
	Art. Nr.	Bezeichnung	
	1034	Miniatur - Kugellager zu Saphirrolle Entspricht OEM-Nr. 635.557	
	1035	Lagerbuchse zu Saphirrolle Entspricht OEM-Nr. 291.474	
	1298	Kugellager rostfrei und geräuschgeprüft Entspricht OEM-Nr. 645.557	
	1299	Radial - Rillenkugellager rostfrei und geräuschgeprüft Entspricht OEM-Nr. 664.167	
	1328	Schrägkugellager (1 Satz = 2 Stück) d= 15,0 D= 32,0 B= 9,0 mm Entspricht OEM-Nr. 607.657	
	1728	Schrägkugellager (1 Satz = 2 Stück) d= 15,0 D= 35,0 B= 11,0 mm passend für AC Challenge / Classic / Evolution / Excellence / Progress und Vertex Entspricht OEM Nr. 694.197	
	1729	Kugellager 6202 passend für AC Classic / Evolution / Progress und Vertex Entspricht OEM Nr. 647.747	
	1736	Kugellager Typ S698 - 2z passend für AC 100 - 300D / 120 - 320 / 150 - 370 / 150 - 350FHSS und Sprint Entspricht OEM Nr. 662.637	
	1760	Kugellager Typ 608 - zz d= 8,0 D= 22,0 B= 7,0 mm Entspricht OEM Nr. 860.127	

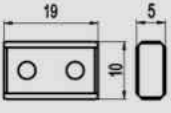

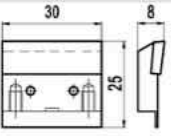
Welo Verschleissteile passend zu Agie - Maschinen

Messer

	Art. Nr.	Bezeichnung	
	1076	Hartmetall Messer passend für AC - Maschinen Entspricht OEM-Nr. 326.614	
	1077	Hartmetall Messer Entspricht OEM-Nr. 326.744	
	1263	Hartmetall Messer passend für AC- / HSS - Maschinen Entspricht OEM-Nr. 417.964	
	1306	Drahtmesser komplett Entspricht OEM-Nr. 417.854	
	1310	Matrize passend für Drahhäcksler Entspricht OEM-Nr. 247.633 oder OEM-Nr. 408.514	
	1325	Hartmetall Messer Entspricht OEM-Nr. 408.574	
	1484	Messer 17 x 6,5 x 24 mm passend für AC Challenge / Classic / Evolution / Excellence / Progress und Vertex Entspricht OEM-Nr. 848.614	
	1485	Matrize D= 20,5 x 8,5 mm passend für AC Challenge / Classic / Evolution / Excellence / Progress und Vertex Entspricht OEM-Nr. 833.974	
	1489	Messer spezial passend für AC Challenge / Classic / Evolution / Excellence / Progress / Sprint und Vertex Entspricht OEM-Nr. 191.593	
	1490	Messer passend für AC Classic / Evolution Entspricht OEM-Nr. 443.134	

Welo Verschleissteile passend zu Agie - Maschinen

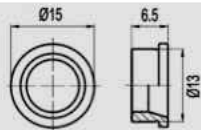
Messer

Welo-Teil	Art. Nr.	Bezeichnung	
	1492	Matrize D= 15 x 6,5 mm passend für AC Classic / Evolution Entspricht OEM-Nr. 448.924	

Welo Verschleissteile passend zu Agie - Maschinen

Drahtausrichtgeräte

Art. Nr.	Bezeichnung
1701	WAD 100 mm Geeignet für Einsatz von hohen Teilen passend für AC 300
1705	WAD 50 mm Entspricht OEM-Nr. 193.392 passend für HSS - Serie
1702	WAD 20 mm Geeignet für Einsatz von niedrigen Teilen passend für AC + F / + SF

Präzisions - Basis - Block aus Granit
unempfindlich gegen Wasser und Temperatureinflüsse
Zum Ausrichten der U - und V - Achse

